

B. Cottenceau; Mehdi Lhommeau; Laurent Hardouin; Jean-Louis Boimond
On timed event graph stabilization by output feedback in dioid

Kybernetika, Vol. 39 (2003), No. 2, [165]--176

Persistent URL: <http://dml.cz/dmlcz/135519>

Terms of use:

© Institute of Information Theory and Automation AS CR, 2003

Institute of Mathematics of the Academy of Sciences of the Czech Republic provides access to digitized documents strictly for personal use. Each copy of any part of this document must contain these *Terms of use*.



This paper has been digitized, optimized for electronic delivery and stamped with digital signature within the project *DML-CZ: The Czech Digital Mathematics Library*
<http://project.dml.cz>

ON TIMED EVENT GRAPH STABILIZATION BY OUTPUT FEEDBACK IN DIOID

B. COTTENCEAU, M. LHOMMEAU, L. HARDOUIN AND J.-L. BOIMOND

This paper deals with *output feedback synthesis* for Timed Event Graphs (TEG) in dioid algebra. The feedback synthesis is done in order to

- stabilize a TEG without decreasing its original production rate,
- optimize the initial marking of the feedback,
- delay as much as possible the tokens input.

Keywords: Time Event Graphs, max-plus algebra, feedback synthesis

AMS Subject Classification: 06F05, 93D15, 93C65, 93B52

1. INTRODUCTION

We recall that a Timed Event Graph (TEG) is a Petri net whose each place has one upstream transition and one downstream transition. Under the earliest functioning rule, a TEG admits a linear representation on $(\max, +)$ or $(\min, +)$ algebra [1, 4].

We are interested here in the problem of TEG stabilization. A TEG is said to be structurally stable if its marking (i. e., its number of tokens) remains limited for all firing sequences of input transitions (this definition is introduced in [1, Chap. 6]).

The property of stability is closely related to the TEG structure. The stabilization problem has been considered by Cohen et al in [3] and more recently by Commault [5]. Commault obtains a sufficient condition of stability for TEG. Such a condition is satisfied if the TEG is made strongly connected by adding paths (i. e., successions of places and transitions) between the output and the input of the TEG. Consequently, each place of the resulting TEG necessarily belongs to a circuit and the marking is then bounded.

In addition, it is shown in [1] that a controllable and observable TEG can be made stable, by adding an output feedback, without altering its production rate. Gaubert has shown in [9] that the number of tokens that must be placed in the feedback to achieve this objective is a resource optimization problem which can be formulated as an integer linear program.

The approach presented here is based, on the one hand, on Gaubert's work [9] and, on the other hand, on the work initiated in [7]. The objective is here to

synthesize a dynamic feedback which minimizes the number of tokens required, under the constraint that feedback keeps the original throughput.

In Section 2, we will recall the algebraic tools necessary to feedback synthesis. We will briefly recall, in Section 3, TEG modelization over the dioid $\mathcal{M}_{in}^{\alpha x}[\gamma, \delta]$ and some periodic properties of TEGs. In Section 4, we will present how an existing feedback in a TEG can be improved and the way in which this can be applied to the problem of TEG stabilization.

2. ALGEBRAIC TOOLS

The reader is invited to consult [1] or [4] for a complete presentation of the following theoretical recalls.

Definition 1. (Dioid, Complete Dioid) A dioid \mathcal{D} is a set endowed with two internal operations denoted \oplus (addition) and \otimes (multiplication), both associative and both having a neutral element denoted ε and e respectively such that \oplus is commutative and idempotent ($\forall a \in \mathcal{D}, a \oplus a = a$), \otimes is distributive with respect to \oplus and ε is absorbing for the product ($\forall a \in \mathcal{D}, \varepsilon \otimes a = a \otimes \varepsilon = \varepsilon$).

A dioid $(\mathcal{D}, \oplus, \otimes)$ is said to be complete if it is closed for infinite sums and if multiplication distributes over infinite sums too. The sum of all its elements is denoted T .

Definition 2. (Order relation) A dioid is endowed with a partial order denoted \succeq and defined by the following equivalence: $a \succeq b \iff a = a \oplus b$.

Theorem 1. (Kleene star theorem) The implicit equation $x = ax \oplus b$ defined over a complete dioid admits $x = a^* \otimes b$ as least solution with $a^* = \bigoplus_{i \geq 0} a^i$. The star operator $*$ is usually called Kleene star.

In ordered sets, equations $f(x) = b$ may have either no solution, one solution, or multiple solutions. In order to give always a unique answer to this problem of mapping inversion, residuation theory [2] provides, under some assumptions, either the greatest solution (in accordance with the partial order) to the inequation $f(x) \preceq b$ or the least solution to $f(x) \succeq b$.

Definition 3. (Isotone mapping) A mapping f defined over ordered sets is said to be isotone if $a \preceq b \Rightarrow f(a) \preceq f(b)$.

Definition 4. (Residuation) Let $f : \mathcal{E} \rightarrow \mathcal{F}$, with (\mathcal{E}, \preceq) and (\mathcal{F}, \preceq) ordered sets. Mapping f is said to be residuated if for all $y \in \mathcal{F}$, the least upper bound of the subset $\{x \in \mathcal{E} | f(x) \preceq y\}$ exists and lies in this subset. It is then denoted $f^\#(y)$. Mapping $f^\#$ is called the residual of f . When f is residuated, $f^\#$ is the unique isotone mapping such that

$$f \circ f^\# \preceq \text{Id} \text{ and } f^\# \circ f \succeq \text{Id}.$$

Theorem 2. ([1]) Let $f : (\mathcal{D}, \oplus, \otimes) \rightarrow (\mathcal{C}, \oplus, \otimes)$ be a mapping defined over complete dioids. Mapping f is residuated if, and only if, $f(\varepsilon) = \varepsilon$ and, $\forall A \subseteq \mathcal{D}$, $f(\bigoplus_{x \in A} x) = \bigoplus_{x \in A} f(x)$.

Corollary 1. Let $L_a : x \mapsto a \otimes x$ and $R_a : x \mapsto x \otimes a$ be defined on a complete dioid. Mappings L_a and R_a are both residuated. Their residuals will be denoted respectively $L_a^\sharp(x) = a \dot{\setminus} x$ and $R_a^\sharp(x) = x \dot{\setminus} a$.

Proof. By definition, ε is absorbing for \otimes and product distributes over sums in complete dioids. \square

Definition 5. (Mapping Restriction) Let $f : E \rightarrow F$ be a mapping and $A \subseteq E$ be a subset. We will denote by $f|_A : A \rightarrow F$ the mapping defined by the equality $f|_A = f \circ \text{Id}|_A$ where $\text{Id}|_A : A \rightarrow E$ is the canonical injection. Identically, let $B \subseteq F$ with $\text{Im} f \subseteq B$. Mapping ${}_B f$ will be defined by the equality $f = \text{Id}|_B \circ {}_B f$ where $\text{Id}|_B : B \rightarrow F$ is the canonical injection.

3. TEG DESCRIPTION

3.1. Dioid $\mathcal{M}_{in}^{ax}[\gamma, \delta]$

The input-output behavior of a TEG may be represented by a transfer relation in some particular dioids. Hereafter, we will essentially represent TEG behavior on the dioid $\mathcal{M}_{in}^{ax}[\gamma, \delta]$. Let us recall that the dioid $\mathcal{M}_{in}^{ax}[\gamma, \delta]$ is formally the quotient dioid of $\mathbb{B}[\gamma, \delta]$, the set of formal power series in two variables (γ, δ) with Boolean coefficients and with exponents in \mathbb{Z} , by the equivalence relation $x \mathcal{R} y \iff \gamma^*(\delta^{-1})^* x = \gamma^*(\delta^{-1})^* y$ (see [1],[4] for an exhaustive presentation). The dioid $\mathcal{M}_{in}^{ax}[\gamma, \delta]$ is complete with a bottom element $\varepsilon = \gamma^{+\infty} \delta^{-\infty}$ and a top element $T = \gamma^{-\infty} \delta^{+\infty}$. Let us consider a representative $s = \bigoplus_{i \in \mathbb{N}} f(n_i, t_i) \gamma^{n_i} \delta^{t_i}$ in $\mathbb{B}[\gamma, \delta]$ of an element belonging to $\mathcal{M}_{in}^{ax}[\gamma, \delta]$. The support of s is then defined as $\{(n_i, t_i) | f(n_i, t_i) \neq \varepsilon\}$ and the valuation (resp. degree) of this element, denoted $\text{val}_\gamma(s)$ (resp. $\text{deg}_\delta(s)$) as the lower bound (resp. upper bound) of its support. A series of $\mathcal{M}_{in}^{ax}[\gamma, \delta]$ is said polynomial if its support is finite. When an element of $\mathcal{M}_{in}^{ax}[\gamma, \delta]$ is used to code a set of information concerning a transition of a TEG, then a monomial $\gamma^k \delta^t$ may be interpreted as: *the kth event occurs at least at date t*.

3.2. Realizability, periodicity and rationality

The transfer series of a TEG have some properties of causality and periodicity that are recalled below.

Definition 6. (Causality) A series $h \in \mathcal{M}_{in}^{ax}[\gamma, \delta]$ is said to be causal either if ($h = \varepsilon$) or ($\text{val}_\gamma(h) \geq 0$ and $h \succeq \gamma^{\text{val}_\gamma(h)}$). The set of causal elements of $\mathcal{M}_{in}^{ax}[\gamma, \delta]$ has a complete dioid structure denoted $\mathcal{M}_{in}^{ax+}[\gamma, \delta]$. A matrix is said to be causal if each of its entries is causal.

Definition 7. (Periodicity) A series $h \in \mathcal{M}_{in}^{ax}[\gamma, \delta]$ is said to be periodic if there exist two polynomials p and q and a monomial $r = \gamma^\nu \delta^\tau$ such that $h = p \oplus qr^*$. The ratio $\lambda = \nu/\tau$ is called the production rate of the series. The set of periodic series of $\mathcal{M}_{in}^{ax}[\gamma, \delta]$ has a dioid structure denoted $\mathcal{M}_{in}^{ax\text{per}}[\gamma, \delta]$. A matrix $H \in \mathcal{M}_{in}^{ax}[\gamma, \delta]^{p \times m}$ is said to be periodic if all its entries are periodic. The production rate of this periodic matrix is then defined as $\bar{\lambda} = \min_{1 \leq i \leq p, 1 \leq j \leq m} \lambda_{ij}$.

Definition 8. (Realizability) An element $H \in \mathcal{M}_{in}^{ax}[\gamma, \delta]^{p \times m}$ is said to be realizable if there exist four matrices $A1, A2, B$ and C with entries in $\{\varepsilon, e\}$ such that $H = C(\gamma A1 \oplus \delta A2)^* B$.

Remark 1. In other words, H is realizable if there exists a TEG whose transfer is H .

Definition 9. (Rational) A series $h \in \mathcal{M}_{in}^{ax}[\gamma, \delta]$ is rational if it may be written as a finite composition of sums, products and Kleene stars of elements belonging to the set $\{\varepsilon, e, \gamma, \delta\}$. A matrix is said to be rational if all its entries are rational.

The following theorem recalls that the input-output transfer of a TEG is characterized by periodic properties.

Theorem 3 ([4]) Let $H \in \mathcal{M}_{in}^{ax}[\gamma, \delta]^{p \times m}$. The following statements are equivalent

- H is periodic and causal.
- H is rational.
- H is realizable.

Proposition 1. The canonical injection $\text{Id}_{|+} : \mathcal{M}_{in}^{ax+}[\gamma, \delta] \rightarrow \mathcal{M}_{in}^{ax}[\gamma, \delta], x \mapsto x$ is residuated. Its residual will be denoted $\text{Pr}_+(x)$.

Proof. According to Theorem 2, it suffices to remark that the canonical injection verifies $\forall A \subseteq \mathcal{M}_{in}^{ax+}[\gamma, \delta], \text{Id}_{|+}(\bigoplus_{x \in A} x) = \bigoplus_{x \in A} x$. □

Practically, for all $x \in \mathcal{M}_{in}^{ax}[\gamma, \delta]$, the computation of $\text{Pr}_+(x)$ is obtained by:

$$\text{Pr}_+(\bigoplus_{i \in \mathbb{N}} f(n_i, t_i) \gamma^{n_i} \delta^{t_i}) = \bigoplus_{i \in \mathbb{N}} g(n_i, t_i) \gamma^{n_i} \delta^{t_i}$$

where

$$g(n_i, t_i) = \begin{cases} f(n_i, t_i) & \text{if } (n_i, t_i) \geq (0, 0) \\ \varepsilon & \text{otherwise.} \end{cases}$$

Theorem 4. ([8, 11]) Let $s1, s2 \in \mathcal{M}_{in}^{ax\text{per}}[\gamma, \delta]$. Then, $s1 \& s2 \in \mathcal{M}_{in}^{ax\text{per}}[\gamma, \delta]$.

Proposition 2. Let $s \in \mathcal{M}_{in}^{ax\text{per}}[\gamma, \delta]$ be a periodic series. $\text{Pr}_+(s) \in \mathcal{M}_{in}^{ax\text{rat}}[\gamma, \delta]$ is the greatest rational element less than or equal to s .

Proof. (sketch of proof) see [6] for further details. The proof consists in remarking that $\forall s \in \mathcal{M}_{in}^{ax\text{per}}[\gamma, \delta]$, $\text{Pr}_+(s)$ belongs to $\mathcal{M}_{in}^{ax\text{per}}[\gamma, \delta]$ too. Moreover, $\text{Pr}_+(s) \in \mathcal{M}_{in}^{ax+}[\gamma, \delta]$. According to Theorem 3, such an element is then rational. \square

Proposition 3. Let $a, b \in \mathcal{M}_{in}^{ax\text{rat}}[\gamma, \delta]$. The element $\text{Pr}_+(a \bowtie b)$ is the greatest rational solution of $a \otimes x \preceq b$. In that sense, we can consider that $L_a^{\text{rat}} : \mathcal{M}_{in}^{ax\text{rat}}[\gamma, \delta] \rightarrow \mathcal{M}_{in}^{ax\text{rat}}[\gamma, \delta]$, $x \mapsto a \otimes x$ is residuated.

Proof. Since a and b are rational, they are periodic too (cf. Theorem 3). Therefore, according to Theorem 4, $a \bowtie b$ is a periodic element but not necessarily causal¹. Furthermore, according to Proposition 2, $\text{Pr}_+(a \bowtie b)$ is then the greatest rational solution of $a \otimes x \preceq b$. \square

4. FEEDBACK SYNTHESIS FOR TEG

4.1. Greatest feedback

In the previous section, we have recalled that a TEG can be represented by its input-output transfer. For instance, considering a TEG with m inputs and p outputs, its input-output behavior may be simply written $Y = HU$, with $H \in \mathcal{M}_{in}^{ax\text{rat}}[\gamma, \delta]^{p \times m}$ a rational matrix.

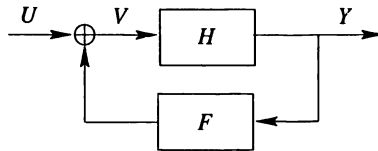

Fig. 1. System H with an output feedback F .

Figure 1 represents the block diagram of a system denoted H on which has been added an output feedback F . By applying Theorem 1, the closed-loop transfer of Figure 1 is

$$Y = H(FH)^*U$$

where $H \in \mathcal{M}_{in}^{ax\text{rat}}[\gamma, \delta]^{p \times m}$ is the open-loop transfer and $F \in \mathcal{M}_{in}^{ax\text{rat}}[\gamma, \delta]^{m \times p}$ is the output feedback transfer. Later on, we will denote by M_H the following mapping

$$M_H : \begin{array}{ccc} \mathcal{M}_{in}^{ax}[\gamma, \delta]^{m \times p} & \rightarrow & \mathcal{M}_{in}^{ax}[\gamma, \delta]^{p \times m}, \\ X & \mapsto & H(XH)^*. \end{array}$$

¹For instance, $\gamma\delta$ and $\gamma^2\delta^2$ are periodic and causal series, nevertheless $\gamma^2\delta^2 \bowtie \gamma\delta = \gamma^{-1}\delta^{-1}$ is not causal.

The mapping M_H represents the way in which a feedback F modifies the closed-loop transfer of a system H . In particular, M_H is isotone since it is a composition of isotone mappings.

Remark 2. $M_H(X)$ may also be written as $(HX)^*H$ since $H(XH)^* = H \oplus HXH \oplus HXH^2 \oplus \dots = (HX)^*H$.

Thanks to Theorem 2, one can check that M_H , defined over complete dioids, is not residuated. Indeed, $M_H(a \oplus b) \neq M_H(a) \oplus M_H(b)$. Nevertheless, the following result shows that there exists a restriction of M_H that is residuated.

Proposition 4. Let us consider the mapping

$$\begin{aligned} \text{Im}_{M_H} M_H : \mathcal{M}_{in}^{ax}[\gamma, \delta]^{m \times p} &\rightarrow M_H(\mathcal{M}_{in}^{ax}[\gamma, \delta]^{m \times p}), \\ X &\mapsto H(XH)^*. \end{aligned}$$

$\text{Im}_{M_H} M_H$ is residuated and its residual is

$$\begin{aligned} (\text{Im}_{M_H} M_H)^\sharp : M_H(\mathcal{M}_{in}^{ax}[\gamma, \delta]^{m \times p}) &\rightarrow \mathcal{M}_{in}^{ax}[\gamma, \delta]^{m \times p}, \\ X &\mapsto H \bowtie X \phi H. \end{aligned}$$

Proof. This result rests on L_a and R_a residuation (cf. Corollary 1). It suffices to show that inequality

$$H(XH)^* \preceq H(aH)^* \tag{1}$$

admits a greatest solution $\forall a \in \mathcal{M}_{in}^{ax}[\gamma, \delta]^{m \times p}$. By considering the Kleene star operator, (1) amounts to satisfying the infinite sequence of inequalities

$$HXH \preceq H(aH)^*, H(XH)^2 \preceq H(aH)^*, \text{ etc.}$$

Indeed, once the first one is satisfied, the second one follows since

$$\begin{aligned} H(XH)^2 &= (HXH)(XH) \\ &\preceq H(aH)^*(XH) \\ &= (Ha)^*HXH \\ &\quad \text{since } (Ha)^*H = H(aH)^* \\ &\preceq (Ha)^*H(aH)^* \\ &= H(aH)^*(aH)^* \\ &= H(aH)^* \\ &\quad \text{since } (aH)^*(aH)^* = (aH)^*. \end{aligned}$$

The same holds true recursively for the next inequalities. Hence we can concentrate on the first one only, and clearly $H \bowtie (H(aH)^*) \phi H$ provides the answer. \square

Proposition 5. Let us consider a TEG whose transfer is $H \in \mathcal{M}_{in}^{axrat}[\gamma, \delta]^{p \times m}$ endowed with an output feedback whose transfer is $F \in \mathcal{M}_{in}^{axrat}[\gamma, \delta]^{m \times p}$. Then, $\hat{F}_+ = \text{Pr}_+(H \bowtie M_H(F) \phi H)$ is the greatest realizable feedback such that $M_H(F) = M_H(\hat{F}_+)$.

Proof. Clearly, $M_H(F) \in \text{Im}M_H$. So, according to Proposition 4, since $\text{Im}M_H | M_H$ is residuated, inequation

$$M_H(X) \preceq M_H(F) \tag{2}$$

admits $\hat{F} = H \bowtie M_H(F) \phi H$ as greatest solution. In particular, since for $X = F$ the equality of (2) is verified, \hat{F} is then the greatest solution to equation $M_H(X) = M_H(F)$. In other hand, $M_H(F)$ is realizable, then periodic (cf. Theorem 3), since it represents the closed-loop transfer. Therefore, according to Theorem 4, $H \bowtie M_H(F) \phi H$ is a periodic matrix but not necessarily a causal matrix. According to Proposition 2, $\hat{F}_+ = \text{Pr}_+(H \bowtie M_H(F) \phi H)$ is the greatest rational solution of $M_H(X) = M_H(F)$. \square

Remark 3. Another interpretation consists in saying that for any realizable system H closed by a realizable feedback F , there is an optimal realizable feedback preserving the transfer of closed-loop system. Since $\hat{F}_+ \succeq F$, the system \hat{F}_+ delays the input of tokens in system H , compared to the feedback F , while ensuring the same output. So, compared to the system F , the feedback \hat{F}_+ decreases the number of tokens, or their sojourn times, in the system H .

4.2. Stabilization of TEG

For a TEG, the property of stability essentially means that tokens do not accumulate indefinitely inside the graph or differently that the marking remains bounded for all inputs. This property is obtained when all transitions fire with the same average frequency.

A TEG is said to be structurally controllable (resp. observable) if every internal transition can be reached by a direct path from at least one input transition (resp. is the origin of at least one direct path to some output transition) (see [1]). It has been shown that a structurally controllable and observable TEG can be made stable by adding an output feedback [3, 11]. Indeed, as soon as all transitions belong to a single strongly connected component, the TEG is stable. Therefore, it suffices that output feedback makes the TEG strongly connected to enforce stability. Moreover, stability may be obtained in order to preserve initial TEG production rate. The following theorem formalizes this result.

Theorem 5. ([1]) Any structurally controllable and observable event graph can be made internally stable by output feedback without altering its original throughput.

4.2.1. Resource optimization in feedback

According to Theorem 5, a TEG can be made stable while preserving its intrinsic throughput. Obviously, this feedback stabilization requires some amount of initial tokens in feedback arcs. In manufacturing context, for instance when a TEG describes a production system, the initial feedback marking can represent some resources like transport means (used to convey parts) or recyclable machines. Consequently, it is particularly significant to limit as much as possible their number. Here, we consider the problem of feedback marking minimization under both constraints of TEG stabilization and production rate preserving. This resource optimization problem, described more precisely hereafter, is tackled², and solved, by Gaubert in [9].

Let us consider a TEG made up of m inputs and p outputs. Arcs provided with a place are added between outputs and inputs so that the TEG becomes strongly connected³. When strong connectedness is reached, the problem consists in calculating the minimal number of tokens to be placed in each of these arcs in order to preserve the throughput of the open-loop system.

The transfer of feedback system can be represented by a matrix $F = (F_{ij}) \in \mathcal{M}_{in}^{q \times rat}[[\gamma, \delta]]^{p \times m}$ where $F_{ij} = \gamma^{q_{ij}}$ if q_{ij} tokens are initially allocated to the place located between output j and input i , and $F_{ij} = \varepsilon$ if there is no arc.

The problem lies in the computation and minimization of $q = \{q_{ij}\}$ in order that the closed-loop system keeps the same production rate as the open-loop one. Gaubert [9] has shown that such a problem may be solved as an integer linear programming problem where the linear cost function is

$$J(q) = \sum_{i=1, j=1}^{i=m, j=p} \alpha_{ij} q_{ij},$$

with α_{ij} a price associated to each resource, and the constraint is

$$\lambda(q) \geq \bar{\lambda},$$

where $\bar{\lambda}$ is the production rate of the open-loop system and $\lambda(q)$ is the production rate with feedback.

If we denote $w_{N_c}(q)$ (resp. w_{T_c}) the (classical) sum of tokens (resp. holding times) in a circuit c , then

$$\lambda(q) = \min_c \frac{w_{N_c}(q)}{w_{T_c}},$$

i. e., for each elementary circuit the following constraint will be satisfied

$$w_{N_c}(q) \geq \bar{\lambda} \times w_{T_c}.$$

The solution of this integer linear program yields q_{ij} tokens that must be placed in each feedback arc. We denote this feedback by $F_{\mathcal{R}\mathcal{O}}$. Then, $F_{\mathcal{R}\mathcal{O}}$ ensures closed-loop stability, preserves the same production rate and minimizes the cost function.

²Other authors have solved such a problem but not necessarily with (max, +) approaches.

³Practically, it is not always necessary to connect all the outputs to all the inputs to obtain strong connectedness.

4.2.2. Synthesis of a greater stabilizing feedback

We propose here to improve the feedback obtained above by computing the greatest dynamic feedback which preserves $M_H(F_{\mathcal{RO}})$.

Proposition 6. Let us denote $F_{\mathcal{RO}}$ a feedback loop obtained by solving a resource optimization problem. The feedback loop

$$\hat{F}_{\mathcal{RO}_+} = \text{Pr}_+(H \bowtie M_H(F_{\mathcal{RO}}) \not\phi H)$$

is the greatest realizable feedback such that $M_H(F_{\mathcal{RO}}) = M_H(\hat{F}_{\mathcal{RO}_+})$.

Proof. Direct from Proposition 5. □

This feedback can be seen as a refinement to the solution brought by Gaubert in [9]. Indeed, as we have explained in Remark 3, feedback $\hat{F}_{\mathcal{RO}_+}$ verifies $\hat{F}_{\mathcal{RO}_+} \succeq F_{\mathcal{RO}}$. Therefore, feedback $\hat{F}_{\mathcal{RO}_+}$ releases input firings latter than with feedback $F_{\mathcal{RO}}$ while ensuring the same output and the same resource number in each feedback. Indeed, since the initial marking (i. e., the resource number) of a path described by a periodic series s is equal to $\text{val}_\gamma(s)$, we obtain

$$\begin{aligned} \hat{F}_{\mathcal{RO}_+} \succeq F_{\mathcal{RO}} &\iff \forall i, j \hat{F}_{\mathcal{RO}_{+ij}} \succeq F_{\mathcal{RO}_{ij}} \\ &\Rightarrow \forall i, j \text{val}_\gamma(\hat{F}_{\mathcal{RO}_{+ij}}) \leq \text{val}_\gamma(F_{\mathcal{RO}_{ij}}). \end{aligned}$$

The last statement means that the resource number of each path of feedback $\hat{F}_{\mathcal{RO}_+}$ is less than or equal to the one of $F_{\mathcal{RO}}$. In the other hand, $M_H(\hat{F}_{\mathcal{RO}_+}) = M_H(F_{\mathcal{RO}})$, and $\text{val}_\gamma(F_{\mathcal{RO}_{ij}})$ is the minimal number of tokens which allows to minimize $J(q)$ while preserving the production rate. This latest statement leads to the equality $\text{val}_\gamma(\hat{F}_{\mathcal{RO}_{+ij}}) = \text{val}_\gamma(F_{\mathcal{RO}_{ij}})$.

4.2.3. Illustrative example

We present here how the preceding results can be implemented. Let us consider the structurally controllable and observable TEG drawn in solid lines in Figure 2. Its transfer matrix in $\mathcal{M}_{in}^{ax}[\gamma, \delta]^{2 \times 2}$ is

$$H = \begin{pmatrix} \delta^6(\gamma\delta)^* & \delta^7(\gamma\delta)^* \\ \varepsilon & \delta^{20}(\gamma\delta^{15})^* \end{pmatrix}.$$

From this transfer matrix, we deduce that the TEG production rate is $\bar{\lambda} = 1/15$ (see Definition 7). This TEG represents a production unit with 4 machines denoted $M1$ to $M4$. Because of the difference of production rates of machines constituting this workshop, one notices that the TEG model is not stable. Indeed, by firing all inputs an infinite number times at a given date we can observe an accumulation of tokens upstream of machine $M4$. Therefore, stability of that system can be obtained by adding an output feedback. It is sufficient to make the TEG strongly connected to

ensure its stability. In that particular case, the TEG becomes strongly connected by adding a feedback of the form:

$$F = \begin{pmatrix} \gamma^{q_{11}} & \varepsilon \\ \gamma^{q_{21}} & \gamma^{q_{22}} \end{pmatrix}.$$

We consider here the resource optimization problem in order to minimize the following cost function $J(q) = q_{11} + q_{21} + q_{22}$ (i. e., $\alpha_{ij} = 1$). This problem can be solved by considering the sum of tokens and temporization of each elementary circuit⁴ which yields the TEG production rate denoted $\lambda(q)$:

$$\lambda(q) = \min \left(\frac{1}{15}, \frac{q_{11}}{6}, \frac{q_{21}}{7}, \frac{q_{22}}{20} \right).$$

Therefore, for $q = (1, 1, 2)$, cost $J(q)$ is minimum, i. e.,

$$F_{\mathcal{RO}} = \begin{pmatrix} \gamma & \varepsilon \\ \gamma & \gamma^2 \end{pmatrix}.$$

This stabilizing feedback that keeps original throughput and minimizes resources number (tokens) is drawn in dotted lines in Figure 2. On the basis of this solution

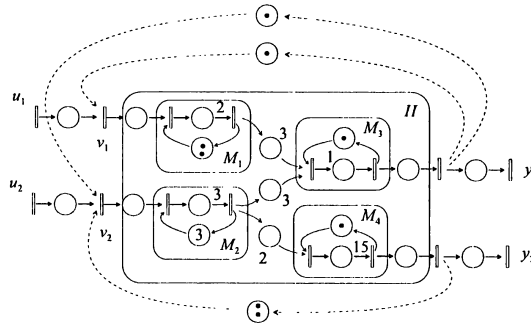

Fig. 2. System H with feedback $F_{\mathcal{RO}}$.

$F_{\mathcal{RO}}$ (obtained by a linear programming approach) and according to Proposition 6, we can refine this result by computing $\hat{F}_{\mathcal{RO}+} = \text{Pr}_+(H \bowtie M_H(F_{\mathcal{RO}}) \phi H)$. We do not detail calculus here. The result obtained is:

$$\begin{aligned} \hat{F}_{\mathcal{RO}+11} &= \gamma\delta \oplus \gamma^2\delta^8 \oplus \gamma^3\delta^{21}(\gamma\delta^{15})^* \\ \hat{F}_{\mathcal{RO}+12} &= \gamma^2\delta(\gamma\delta^{15})^* \\ \hat{F}_{\mathcal{RO}+21} &= \gamma \oplus \gamma^2\delta^7 \oplus \gamma^3\delta^{20}(\gamma\delta^{15})^* \\ \hat{F}_{\mathcal{RO}+22} &= \gamma^2(\gamma\delta^{15})^* \end{aligned}$$

⁴The naive enumeration of elementary circuits is simpler than writing the linear program. But, for large graphs, such an enumeration becomes practically impossible (for a complete graph with n vertices, the enumeration complexity is $O((n-1)!)$). Gaubert's approach [9] allows to consider only n^2 inequalities.

A realization of that system is drawn in Figure 3.

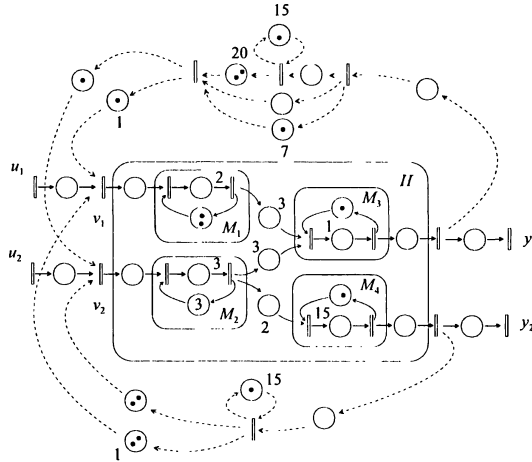

Fig. 3. System H with feedback $F_{\mathcal{R}\mathcal{O}_+}$.

Remark 4. We can notice that feedback $\hat{F}_{\mathcal{R}\mathcal{O}_+}$ has an arc $y_1 \rightarrow u_2$ that does not exist in feedback $F_{\mathcal{R}\mathcal{O}}$.

Remark 5. This synthesis has been done by using free software tools available on [10]. This tools allow manipulating periodic series in dioids $\overline{\mathbb{Z}}_{\max}[[\gamma]]$, $\overline{\mathbb{Z}}_{\min}[[\delta]]$ and $\mathcal{M}_{in}^{ax}[[\gamma, \delta]]$.

(Received April 2, 2002.)

REFERENCES

- [1] F. Baccelli, G. Cohen, G. J. Olsder, and J. P. Quadrat: Synchronization and Linearity: An Algebra for Discrete Event Systems. Wiley, New York 1992.
- [2] T. S. Blyth and M. F. Janowitz: Residuation Theory. Pergamon Press, Oxford 1972.
- [3] G. Cohen, P. Moller, J. P. Quadrat, and M. Viot: Linear system theory for discrete-event systems. In: Proc. 23rd IEEE Conference on Decision and Control, Las Vegas 1984.
- [4] G. Cohen, P. Moller, J. P. Quadrat, and M. Viot: Algebraic tools for the performance evaluation of discrete event systems. IEEE Proceedings: Special Issue on Discrete Event Systems 77 (1989), 1, 39–58.
- [5] C. Commault: Feedback stabilization of some event graph models. IEEE Trans. Automat. Control 43 (1998), 10, 1419–1423.
- [6] B. Cottenceau: Contribution à la commande de systèmes à événements discrets: synthèse de correcteurs pour les graphes d'événements temporisés dans les diodes. Ph.D. Thesis (in French). ISTIA, Université d'Angers 1999.
- [7] B. Cottenceau, L. Hardouin, J. L. Boimond, and J. L. Ferrier: Synthesis of greatest linear feedback for timed event graphs in dioid. IEEE Trans. Automat. Control 44 (1999), 6, 1258–1262.

- [8] S. Gaubert: Théorie des systèmes linéaires dans les dioïdes. Ph.D. Thesis (in French). Ecole des Mines de Paris, Paris 1992.
- [9] S. Gaubert: Resource optimization and $(\min, +)$ spectral theory. IEEE Trans. Automat. Control 40 (1992), 11, 1931–1934.
- [10] Software tools for manipulating periodic series:
<http://www.istia.univ-angers.fr/hardouin/outils.html>.
- [11] Max Plus: Second order theory of min-linear systems and its application to discrete event systems. In: Proc. 30th IEEE Conference on Decision and Control, Brighton 1991.

Dr. Bertrand Cottenceau, Dr. Mehdi Lhommeau, Dr. Laurent Hardouin and Pr. Jean-Louis Boimond, Laboratoire d'Ingénierie des Systèmes Automatisés, Angers, 62 avenue Notre-Dame du Lac 49 000 Angers. France.
e-mails: cottenceau, lhommeau, hardouin, boimond@istia.univ-angers.fr.