

Jiří Adámek; Jiří Rosický

On pure quotients and pure subobjects

Czechoslovak Mathematical Journal, Vol. 54 (2004), No. 3, 623–636

Persistent URL: <http://dml.cz/dmlcz/127916>

Terms of use:

© Institute of Mathematics AS CR, 2004

Institute of Mathematics of the Czech Academy of Sciences provides access to digitized documents strictly for personal use. Each copy of any part of this document must contain these *Terms of use*.



This document has been digitized, optimized for electronic delivery and stamped with digital signature within the project *DML-CZ: The Czech Digital Mathematics Library* <http://dml.cz>

ON PURE QUOTIENTS AND PURE SUBOBJECTS

J. ADÁMEK, Braunschweig, and J. ROSICKÝ, Brno

(Received October 26, 2001)

Abstract. In the theory of accessible categories, pure subobjects, i.e. filtered colimits of split monomorphisms, play an important role. Here we investigate pure quotients, i.e., filtered colimits of split epimorphisms. For example, in abelian, finitely accessible categories, these are precisely the cokernels of pure subobjects, and pure subobjects are precisely the kernels of pure quotients.

Keywords: pure quotient, pure subobject, locally presentable category, semi-abelian category, abelian category

MSC 2000: 18A99, 18E99

The concept of a λ -pure subobject stems from module and model theory, and has been first categorically formulated by S. Fakir [3]. In our monograph [1] we have simplified that definition, and have proved that λ -pure subobjects play a central role in the theory of accessible categories of C. Lair [5] and M. Makkai, R. Paré [6]. In particular, the following results hold (recall that “accessibly embedded” means full and closed under λ -filtered colimits for some regular cardinal λ):

- (a) every accessibly embedded, accessible subcategory \mathcal{K} is closed in \mathcal{K} under λ -pure subobjects for some λ ,
- (b) conversely, all accessibly embedded subcategories of accessible categories closed under λ -pure subobjects are accessible, and
- (c) every accessible category has enough λ -pure subobjects in the sense that it has arbitrarily large cardinals α such that every α -presentable subobject of an arbitrary object A can be extended to an α -presentable λ -pure subobject of A .

The first author was supported by the Grant Agency of the Czech Republic under the grant No. 201/99/0310, the second author by the Ministry of Education of the Czech Republic under the project MSM 149100009.

The present note is devoted to the study of the “dual” concept: λ -pure quotient. It can be defined, in categories with pullbacks, as a λ -filtered colimit of split quotients. This concept has been studied in categories of modules (see, e.g., [7]) and is closely related to λ -pure subobjects. For example, in abelian, finitely accessible categories, λ -pure quotients are precisely the cokernels of λ -pure subobjects, and vice versa. Of the three properties (a)–(c) mentioned above only the first has a complete analogy: every accessible, accessibly embedded subcategory of an accessible category is closed under λ -pure quotients for some λ . We show counterexamples to the possibility of “dualizing” (b) and (c).

Recall that a morphism $f: A \rightarrow B$ is called a λ -pure subobject provided that in every commutative square

$$(1) \quad \begin{array}{ccc} X & \xrightarrow{g} & Y \\ u \downarrow & & \downarrow v \\ A & \xrightarrow{f} & B \end{array}$$

with X and Y λ -presentable the morphism u factors through g , i.e., there exists a diagonal morphism

$$(2) \quad \begin{array}{ccc} X & \xrightarrow{g} & Y \\ u \downarrow & \swarrow d & \downarrow v \\ A & \xrightarrow{f} & B \end{array}$$

making the upper triangle commutative. We define below a λ -pure quotient as a morphism $f: A \rightarrow B$ which is projective w.r.t. all λ -presentable objects. In all categories with an initial object 0 this is formally very similar to the above definition: here we request that in every commutative square (1) there be a diagonal such that the lower triangle of (2) commutes. (This, for $X = 0$, is precisely the projectivity w.r.t. λ -presentable objects Y .)

We are going to prove a number of results which show parallels between λ -pure subobjects and λ -pure quotients. For example, given an α -presentable object A (for α “sufficiently” large), every λ -pure subobject of A is also α -presentable, and every λ -pure quotient of A is also α -presentable. Furthermore, in locally λ -presentable categories, λ -pure subobjects are regular monomorphisms, and λ -pure quotients are regular epimorphisms. The most dramatic difference between those two concepts, on the other hand, is that there are locally finitely presentable categories with arbitrarily large objects (measured by their presentation rank) having no proper λ -pure quotient.

Throughout the paper we work with λ -accessible categories (see [6] or [1]), where λ is a regular cardinal (i.e. an infinite cardinal which is not a sum of a smaller number

of smaller cardinals). These are defined to be the categories \mathcal{K} which have λ -filtered colimits and a set \mathcal{K}_λ of λ -presentable objects (representing all λ -presentable objects up to isomorphism—and considered as a full subcategory of \mathcal{K}) such that every object A of \mathcal{K} is a λ -filtered colimit of objects of \mathcal{K}_λ . Equivalently: $A = \text{colim } D$ where $D: \mathcal{K}_\lambda \downarrow A \rightarrow \mathcal{K}$ is the *canonical diagram* mapping arrows $h: K \rightarrow A$ ($K \in \mathcal{K}_\lambda$) to their domains K . See e.g. [1].

Definition 1. A morphism $f: A \rightarrow B$ in a category is called a λ -*pure quotient* (for a regular cardinal λ) provided that it is projective w.r.t. λ -presentable objects. We say *pure* if $\lambda = \aleph_0$.

Explicitly for every λ -presentable object X , all morphisms $X \rightarrow B$ factor through f :

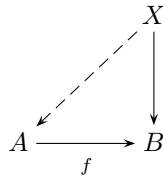

Example 2.

- (a) Split epimorphisms are λ -pure quotients for all λ . Conversely, in accessible categories, if a morphism $f: A \rightarrow B$ is a λ -pure quotient for all λ , then it is a split epimorphism: take λ such that B is λ -presentable.
- (b) λ -filtered colimits of λ -pure quotients in \mathcal{K} (formed in the category $\mathcal{K}^{\rightarrow}$ of morphisms of \mathcal{K}) are λ -pure quotients, as can be easily verified.
- (c) In abelian, λ -accessible categories, all cokernels of λ -pure subobjects are λ -pure quotients. In fact, let $m: A \rightarrow B$ be a λ -pure subobject in \mathcal{K} . As proved in [1], m is a λ -filtered colimit of split subobjects $m_i: A \rightarrow B_i$ ($i \in I$) in $A \downarrow \mathcal{K}$; denote by $\beta_i: (B_i, m_i) \rightarrow (B, m)$ the colimit cocone. For each i denote by $c_i: B_i \rightarrow C_i$ a cokernel of m_i ; since m_i is a split monomorphism, c_i is a split epimorphism (in fact, split monomorphisms are precisely the injections of biproducts). Moreover, the C_i 's form an obvious diagram with diagram scheme I such that the c_i 's form a natural transformation. This defines a diagram in $\mathcal{K}^{\rightarrow}$: let

$$c: B \rightarrow C$$

denote a colimit whose colimit cocone

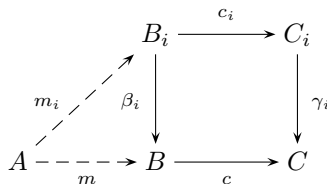

extends the above colimit cocone β_i . Then c is a λ -pure quotient, see the preceding example. And c is a cokernel of m .

Proposition 3. *In every λ -accessible category \mathcal{K} with pullbacks, λ -pure quotients are precisely the λ -filtered colimits, in $\mathcal{K}^{\rightarrow}$, of split epimorphisms of \mathcal{K} .*

Remark. We will see in the proof that, moreover, the colimit cocone (in $\mathcal{K}^{\rightarrow}$) is formed by pullback squares in \mathcal{K} .

Proof. One implication is Example 2 (a) and (b) above. For the reverse, consider a λ -pure quotient $f: A \rightarrow B$ in \mathcal{K} . Since \mathcal{K} is λ -accessible, B is a λ -filtered colimit of λ -presentable objects; denote by $b_i: B_i \rightarrow B$ ($i \in I$) the colimit cocone. For each i form a pullback of f and b_i :

$$\begin{array}{ccc} A_i & \xrightarrow{f_i} & B_i \\ a_i \downarrow & & \downarrow b_i \\ A & \xrightarrow{f} & B \end{array}$$

Since f is λ -pure, we have $d_i: B_i \rightarrow A$ with $b_i = d_i f$, and this implies that f_i is a split epimorphism (due to $b_i \cdot \text{id} = d_i \cdot f$). Since pullbacks commute with λ -filtered colimits in \mathcal{K} , f is a colimit of the obvious diagram $I \rightarrow \mathcal{K}^{\rightarrow}$ whose object-part assigns f_i to i (with a colimit cocone formed by (a_i, b_i) for $i \in I$). \square

Proposition 4. *Let \mathcal{K} be a λ -accessible category. Then*

(a) *every λ -pure quotient is an epimorphism,*

and

(b) *if \mathcal{K} has pullbacks, every λ -pure quotient is a regular epimorphism.*

Proof. (a) is trivial since all λ -presentable objects form a generator of \mathcal{K} .

(b) Let $f: A \rightarrow B$ be a λ -pure quotient expressed as a λ -filtered colimit, in $\mathcal{K}^{\rightarrow}$, of split epimorphisms $f_i: A_i \rightarrow B_i$ ($i \in I$). Form kernel pairs of f_i :

$$p_i, q_i: E_i \rightarrow A_i \quad (i \in I)$$

to obtain a diagram $i \mapsto E_i$ in \mathcal{K} together with two natural transformations p_i, q_i ($i \in I$). We form a (λ -filtered) colimit E of that diagram. The unique morphisms $p = \text{colim } p_i$ and $q = \text{colim } q_i$ from E to A have a coequalizer f . This follows from $f_i = \text{coeq}(p_i, q_i)$ (recall that f_i is a regular, in fact split, epimorphism) and from the commutation of colimits with coequalizers. \square

Proposition 5. *In every λ -accessible abelian category the following assertions hold:*

- (a) *λ -pure quotients are precisely the cokernels of λ -pure subobjects,*
- and
- (b) *λ -pure subobjects are precisely the kernels of λ -pure quotients.*

Proof. For (a), one implication has been proved as Example 2(c) above, for the reverse implication, consider a λ -pure quotient $c: B \rightarrow C$. Denote by $m: A \rightarrow B$ the kernel of c . Given a commutative square

$$\begin{array}{ccccc} X & \xrightarrow{h} & Y & & \\ \downarrow u & & \downarrow v & & \\ A & \xrightarrow{m} & B & \xrightarrow{c} & C \end{array}$$

with X and Y λ -presentable, it is our task to prove that u factors through h . Since X and Y are λ -presentable, a cokernel $k: Y \rightarrow Z$ of h has the property that Z is λ -presentable. We have

$$cvh = cmu = 0,$$

thus, cv factors through k (via $w: Z \rightarrow C$):

$$\begin{array}{ccccc} X & \xrightarrow{h} & Y & \xrightarrow{k} & Z \\ \downarrow u & \swarrow d' & \downarrow v & \swarrow d & \downarrow w \\ A & \xrightarrow{m} & B & \xrightarrow{c} & C \end{array}$$

Since Z is λ -presentable and c is a λ -pure quotient, there exists $d: Z \rightarrow B$ with $w = cd$. From

$$c(v - dk) = cv - cdk = cv - wk = cv - cv = 0$$

we conclude that there exists $d': Y \rightarrow A$ with

$$md' = v - dk.$$

This is the desired factorization: the equality $u = d'h$ follows from m being a monomorphism, since

$$md'h = (v - dk)h = vh = mu.$$

For (b), one implication has been just proved: kernels of λ -pure quotients are λ -pure. The other implication is 2(c) above. □

Example 6. The category **Rng** of commutative, not necessarily unitary, rings does not have the property that kernels of pure quotients are pure subobjects. In fact, consider the free object on one generator x that can be described as the subring $\mathbb{Z}_0[x]$ of the ring $\mathbb{Z}[x]$ (of all polynomials with integer coefficients) consisting of all polynomials with a root 0. The embedding

$$\mathbb{Z}_0[x] \hookrightarrow \mathbb{Z}[x]$$

does not split (since $\mathbb{Z}_0[x]$ does not have a unit, but a splitting $s: \mathbb{Z}[x] \rightarrow \mathbb{Z}_0[x]$ would yield the unit $s(1)$). Since each of these rings is finitely presentable (for $\mathbb{Z}[x]$ consider generators x and y and equation $xy = x$), it follows that that embedding is not pure. However, this is the kernel of the evaluation-at-0 map $\mathbb{Z}[x] \rightarrow \mathbb{Z}$ which is split by the obvious embedding.

Remark. **Rng** is an example of a category very “near” to abelianness: it is a semi-abelian category in the sense of Janelidze-Márki-Tholen [4]. We do not recall the definition here, but just observe, for readers familiar with that concept, that whereas cokernels do not work, kernels do:

Proposition 7. *Let \mathcal{K} be a λ -accessible, semi-abelian category with a zero object. Then cokernels of λ -pure normal subobjects are λ -pure quotients.*

Remark. The restriction to *normal* subobjects is, unfortunately, forced by the fact that in semi-abelian categories it is not true in general that every λ -pure subobject is normal. Example: in the category of groups the coproduct injections of $\mathbb{Z} + \mathbb{Z}$ are split subobjects which are not normal.

Proof. Since semi-abelian categories have pullbacks, λ -pure subobjects are λ -filtered colimits of split subobjects. In more detail, given $f: A \rightarrow B$ λ -pure, there is a λ -filtered diagram of split subobjects $f_i: A_i \rightarrow B_i$ whose colimit (in $\mathcal{K}^{\rightarrow}$) is f and each of which results by pulling f back along a morphism, see 2.30 in [1]. Thus, if f is normal, each f_i is normal. And the cokernel of f is, of course, a λ -filtered colimit of the cokernels of f_i . Thus, it is sufficient to prove that a cokernel of a split, normal subobject is a split quotient.

Let $f: A \rightarrow B$ be a normal monomorphism split by $s: B \rightarrow A$ and $g: B \rightarrow C$ a cokernel of f . Consider the commutative diagram

$$\begin{array}{ccccc}
 A & \xrightarrow{f} & B & \xrightarrow{g} & C \\
 \text{id } A \downarrow & & \downarrow \langle s, g \rangle & & \downarrow \text{id } C \\
 A & \xrightarrow{i_1} & A \times C & \xrightarrow{p_2} & C
 \end{array}$$

where $i_1 = \langle \text{id}_A, 0 \rangle$ and p_2 is the projection. Since f is normal, f is a kernel of g . Since i_1 is a kernel of p_2 , the Short Five Lemma (see [4]) implies that $\langle s, g \rangle$ is an isomorphism. Hence g splits. \square

Example 8. There are finitely accessible categories with a zero object such that cokernels of pure normal subobjects are not pure.

For example, let \mathcal{K} be the category of graphs with loops and a base point (denoted by $*$), i.e., relational structures with one binary reflexive relation and one constant $*$. Consider the short exact sequence

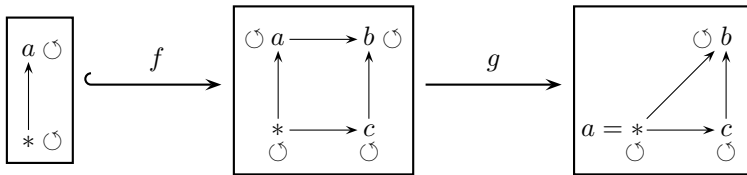

It is clear that f is a split monomorphism, but g is not a split epimorphism. Since the codomain of g is finitely presentable, it follows that g is not a pure quotient.

Corollary 9. In λ -accessible semi-abelian categories all λ -pure quotients are normal.

In fact, split epimorphisms are normal, see 3.2 in [4], and (since finite limits exist and commute with filtered colimits) all λ -filtered colimits of normal quotients are normal.

Remark 10. (1) We have mentioned in the introduction that λ -accessible categories have enough λ -pure subobjects. Nothing similar holds for λ -pure quotients in general. Consider the locally finitely presentable category **Gra** of graphs (sets with a binary relation) and homomorphisms. For every cardinal α , consider the complete graph K_α on α (with an edge between any pair of distinct vertices and without loops). No proper quotient (regular epimorphism with domain K_α) is pure—thus, we have arbitrarily large objects without proper pure quotients! In fact, for every proper quotient $f: K_\alpha \rightarrow X$, the graph X has a loop (i.e., a copy of the terminal object 1 as a subgraph), whereas no morphism $1 \rightarrow K_\alpha$ exists.

(2) In accessible abelian categories, however, Proposition 5 shows that there exist enough λ -pure quotients in the following sense: there are arbitrarily large cardinals α such that for every quotient $f: A \rightarrow B$ with an α -presentable kernel (more precisely: with a kernel whose domain is α -presentable) there exists a λ -pure quotient

$f': A \rightarrow B'$ with an α -presentable kernel together with a factorization

$$\begin{array}{ccc} A & \xrightarrow{f} & B \\ f' \downarrow & \swarrow & \\ & & B' \end{array}$$

Observation 11. λ -pure quotients are closed under composition and are left cancellative. That is, given a commutative triangle

$$\begin{array}{ccc} A & \xrightarrow{f} & B \\ & \searrow h & \downarrow g \\ & & C \end{array}$$

then

$$f, g \text{ } \lambda\text{-pure} \Rightarrow h \text{ } \lambda\text{-pure}$$

and

$$h \text{ } \lambda\text{-pure} \Rightarrow g \text{ } \lambda\text{-pure}.$$

Analogously, λ -pure subobjects are closed under composition and are right cancellative.

Theorem 12. (Pure subobjects and pure quotients preserve the presentation rank.) For every finitely accessible category there exists a cardinal α_0 such that, given an α -presentable object A with $\alpha \geq \alpha_0$, then every pure subobject and every pure quotient of A are α -presentable.

Remark. (i) More precisely, (a) for every pure subobject $B \rightarrow A$, the object B is α -presentable, and (b) for every pure quotient $A \rightarrow B$, the object B is α -presentable.

(ii) The choice of the cardinal α_0 can be made as follows:

$$\alpha_0 = \text{card}(\text{mor } \mathcal{K}_{\text{fin}}) + \aleph_0$$

where \mathcal{K}_{fin} is a full subcategory of \mathcal{K} representing all finitely presentable objects up to isomorphism. For example,

$$\alpha_0 = \aleph_0$$

for the category Ab of abelian groups, and

$$\alpha_0 = \aleph_0 + \text{card } R$$

for the category of right R -modules.

(iii) For λ -accessible categories in general, a slightly less sharp result holds: there exist arbitrarily large presentability ranks preserved by a “ λ -pure subobject” as well as by a “ λ -pure quotient”. That is, arbitrarily large cardinals α satisfying (a) and (b) above (for λ -pure substituting pure).

Proof (of Theorem 12 and Remark). (1) Let \mathcal{K} be finitely accessible and put $\alpha_0 = \text{card}(\text{mor } \mathcal{K}_{\text{fin}}) + \aleph_0$. Then following 2.15 in [1], an object A is α -presentable in \mathcal{K} with $\alpha \geq \alpha_0$ iff A is a split subobject of an α -small filtered colimit of finitely presentable objects (where “ α -small” means that the domain of the diagram in question has less than α morphisms). Let $m: A \rightarrow A' = \text{colim}_{i \in I} A_i$ be such a split monomorphism with each A_i finitely presentable and $\text{card}(\text{mor } I) < \alpha$. Let $a_i: A_i \rightarrow A'$ denote the colimit cocone.

(1a) Given a pure subobject $n: B \rightarrow A$, then the composite $mn: B \rightarrow A'$ is pure. Consider the canonical diagram (forgetful functor of the comma-category) $D: \mathcal{K}_{\text{fin}} \downarrow B \rightarrow \mathcal{K}$ whose colimit is B . For each of its objects, $c: C \rightarrow B$, the morphism $mnc: C \rightarrow A'$ factors (since C is finitely presentable) through some a_i ($i \in I$), say, via $c': C \rightarrow A_i$:

$$\begin{array}{ccc}
 C & \xrightarrow{c'} & A_i \\
 \downarrow c & \swarrow d & \downarrow a_i \\
 B & \xrightarrow{n} A \xrightarrow{m} & A'
 \end{array}$$

Since C and A_i are finitely presentable and mn is pure, it follows that there exists $d: A_i \rightarrow B$ with

$$c = dc'.$$

Thus, the full subcategory \mathcal{D}_0 of $\mathcal{K}_{\text{fin}} \downarrow B$ on all objects of the form $A_i \xrightarrow{d} B$ ($i \in I$ and d arbitrary) is cofinal in $\mathcal{K}_{\text{fin}} \downarrow B$, hence, B is a canonical colimit of the domain-restriction $D_0: \mathcal{D}_0 \rightarrow \mathcal{K}$ of D above. Since \mathcal{D}_0 has less than α objects and, for each pair of objects, at most α_0 ($< \alpha$) morphisms between them, we have $\text{card}(\text{mor } \mathcal{D}_0) < \alpha$. Consequently, $B = \text{colim } D_0$ is α -presentable.

(1b) Given a pure quotient $b: A \rightarrow B$, then for the above m we have an $r: A' \rightarrow A$ satisfying $rm = \text{id}$; this yields a pure quotient $br: A' \rightarrow B$. Consider, again, the canonical diagram $D: \mathcal{K}_{\text{fin}} \downarrow B \rightarrow \mathcal{K}$.

$$\begin{array}{ccc}
 A_i & \xleftarrow{c''} & C \\
 \downarrow a_i & \swarrow c' & \downarrow c \\
 A' & \xrightarrow{r} A \xrightarrow{b} & B
 \end{array}$$

For each of its objects, $c: C \rightarrow B$, we have a factorization through the pure quotient br , say $c = brc'$, and since C is finitely presentable, c' factors through a_i for some $i \in I$:

$$c = bra_i c'' \quad \text{for some } i \in I \text{ and } c'': C \rightarrow A_i.$$

This shows that the objects $bra_i: A_i \rightarrow B$ ($i \in I$) of $\mathcal{K}_{\text{fin}} \downarrow B$ form a cofinal subcategory. The object B is again a colimit of the diagram D restricted to that subcategory, thus, B is α -presentable.

(2) Let \mathcal{K} be λ -accessible. The proof is completely analogous to (1) above with the following modifications: we put $\alpha_0 = \text{card}(\text{mor } \mathcal{K}_\lambda) + \aleph_0$. Then the above characterization of α -presentable objects holds for all cardinals $\alpha > \alpha_0$ with

$$\alpha \triangleright \lambda.$$

This last relation means that every λ -accessible category is α -accessible. (For example, if $\lambda = \aleph_0$, then $\alpha \triangleright \aleph_0$ holds for all infinite cardinals α . This is the reason of the simplified statement in (1).) Here, the only additional fact requested for our proof is that for every cardinal λ there exist arbitrarily large cardinals α with $\alpha \triangleright \lambda$. And, given $\alpha > \alpha_0$ with $\alpha \triangleright \lambda$, then an object of \mathcal{K} is α -presentable iff it is a split subobject of an α -small colimit of λ -presentable objects, see 2.15 in [1]. Now the proof continues as above: for all α -presentable objects with $\alpha > \alpha_0$ and $\alpha \triangleright \lambda$ all λ -pure subobjects as well as all λ -pure quotients are also α -presentable. \square

Proposition 13. *Every accessible, accessibly embedded subcategory of an accessible category \mathcal{K} is closed in \mathcal{K} under λ -pure quotients for some cardinal λ .*

Proof. By 2.19 in [1] there exists, for every accessible and accessibly embedded subcategory \mathcal{A} of \mathcal{K} , a regular cardinal λ such that

- (i) \mathcal{A} and \mathcal{K} are λ -accessible categories
- and
- (ii) \mathcal{A} is closed in \mathcal{K} under λ -filtered colimits and under λ -presentability (i.e., every λ -presentable object of \mathcal{A} is λ -presentable in \mathcal{K}).

Let $f: A \rightarrow B$ be a λ -pure quotient in \mathcal{K} with $A \in \mathcal{A}$. Express A as a λ -filtered colimit of λ -presentable objects in \mathcal{A} with a colimit cocone $a_i: A_i \rightarrow A$ ($i \in I$). We know that B is a canonical colimit of the diagram $D: \mathcal{K}_\lambda \downarrow B \rightarrow \mathcal{K}$ in \mathcal{K} , where \mathcal{K}_λ is a full subcategory of \mathcal{K} representing all λ -presentable objects. For each object $c: C \rightarrow B$ of $\mathcal{K}_\lambda \downarrow B$ there exists, by λ -purity of f , a factorization $c': C \rightarrow A$ with $c = fc'$

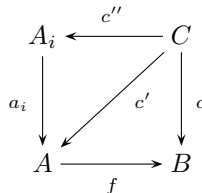

and since \mathcal{A} is closed under λ -filtered colimits and C is λ -presentable, we can find $i \in I$ and $c'' : C \rightarrow A_i$ with $c' = a_i c''$. Thus,

$$c = (fa_i)c''.$$

This shows that the objects $fa_i : A_i \rightarrow B$ of $\mathcal{K}_\lambda \downarrow B$ (recall that \mathcal{A} is closed under λ -presentability) form a cofinal subcategory of $\mathcal{K}_\lambda \downarrow B$. Therefore, B is a colimit of the subdiagram of D restricted to these objects, and thus $A_i \in \mathcal{A}$ implies $B \in \mathcal{A}$. □

Example 14. An accessibly embedded subcategory of **Gra** which is closed under (not only λ -pure) quotients but is not accessible.

Such an example requires an assumption on the set theory we work in: as proved in [1], if our theory satisfies Vopěnka’s Principle:

*no large discrete full subcategory of **Gra** exists,*

then every accessibly embedded subcategory of an accessible category is accessible. Thus, for our example we need to assume the negation of Vopěnka’s Principle (which is true in the set theory whenever no measurable cardinal exists, see [1]).

Thus, we start with a large discrete full subcategory \mathcal{D} of **Gra**. Denote by $\widehat{\mathcal{D}}$ the class of all proper subobjects of the objects of \mathcal{D} . The full subcategory

$$\mathcal{A} = \{A \in \mathbf{Gra}; \text{hom}(A, \widehat{D}) = \emptyset \text{ for all } \widehat{D} \in \widehat{\mathcal{D}}\}$$

is clearly closed under nonempty colimits and quotients. And it contains \mathcal{D} since for $A \in \mathcal{D}$ and $\widehat{D} \in \widehat{\mathcal{D}}$ we have a monomorphism $m : \widehat{D} \rightarrow D$ for some $D \in \mathcal{D}$ and in case a morphism $f : A \rightarrow \widehat{D}$ exists, the discreteness of \mathcal{D} yields $A = D$ and $mf = \text{id}$ —thus, m is an isomorphism.

The category \mathcal{A} cannot be accessible. In fact, if it were, there would exist, since \mathcal{A} is accessibly embedded, a cardinal λ such that \mathcal{A} is λ -accessible and closed under λ -presentability (see 2.19 in [1]). Since \mathcal{D} is large, it contains a graph D of cardinality larger than λ . This is an object of \mathcal{A} that is not a λ -filtered colimit of λ -presentable objects because no proper subobject of D lies in \mathcal{A} .

Remark. (i) The above example contrasts with the following criterion of accessibility of subcategories of an accessible category \mathcal{K} : if \mathcal{A} is an accessibly embedded subcategory of \mathcal{K} , then \mathcal{A} is accessible iff \mathcal{A} is closed under λ -pure subobjects in \mathcal{K} for some λ , see [1].

(ii) For \mathcal{K} abelian and \mathcal{A} closed under kernel pairs in \mathcal{K} , we do have the corresponding fact: if \mathcal{A} is an accessibly embedded subcategory, then \mathcal{A} is accessible iff \mathcal{A} is closed under λ -pure quotients for some λ . This follows from (i) and Proposition 5.

Proposition 15. *In every locally λ -presentable category*

- (i) *λ -pure subobjects are stable under pushout*
- and
- (ii) *λ -pure quotients are stable under pullback.*

Proof. (i) It is easy to verify that split monomorphisms are stable under pushout. Given a pushout

$$\begin{array}{ccc} A & \xrightarrow{m} & B \\ f \downarrow & & \downarrow f' \\ P & \xrightarrow{m'} & Q \end{array}$$

where m is a λ -pure subobject, express m as a λ -filtered colimit of split subobjects $m_i: A \rightarrow B_i$ ($i \in I$) in $A \downarrow \mathcal{K}$ and form pushouts of m_i along f :

$$\begin{array}{ccc} A & \xrightarrow{m_i} & B_i \\ f \downarrow & & \downarrow f'_i \\ P & \xrightarrow{m'_i} & Q_i \end{array}$$

Then Q_i ($i \in I$) form the object part of a λ -filtered diagram in \mathcal{K} with natural transformations $m'_i: \Delta P \rightarrow Q_i$ and $f'_i: B_i \rightarrow Q_i$ ($i \in I$). Since pushouts commute with colimits, we obtain

$$m' = \operatorname{colim}_{i \in I} m'_i \quad \text{in } A \downarrow \mathcal{K},$$

a λ -filtered colimit of split subobjects—thus, m' is a λ -pure subobject.

- (ii) Given a pullback

$$\begin{array}{ccc} Q & \xrightarrow{c'} & P \\ f' \downarrow & & \downarrow f \\ A & \xrightarrow{c} & C \end{array}$$

with c a λ -pure quotient, we prove that c' is a λ -pure quotient. Express c as a λ -filtered colimit of split epimorphisms $c_i: A_i \rightarrow C_i$ ($i \in I$) with a colimit cocone

$$\begin{array}{ccc} A_i & \xrightarrow{c_i} & C_i \\ a_i \downarrow & & \downarrow b_i \\ A & \xrightarrow{c} & C \end{array}$$

where each of the above squares is a pullback (see Proposition 3).

(a) Suppose that P is λ -presentable. Then f factors as $f = b_i f'$ for some $f': P \rightarrow C_i$. Form a pullback of f' along the split epimorphism c_i :

$$\begin{array}{ccc}
 Q & \xrightarrow{c'_i} & P \\
 f'' \downarrow & & \downarrow f' \\
 A_i & \xrightarrow{c_i} & C_i \\
 a_i \downarrow & & \downarrow b_i \\
 A & \xrightarrow{c} & C
 \end{array}$$

Then c'_i is a split epimorphism which is a pullback of c along $b_i f' = f$ (since both of the above adjacent squares are pullbacks).

(b) If P is arbitrary, express P as a λ -filtered colimit of λ -presentable objects with a colimit cocone $p_t: P_t \rightarrow P$ ($t \in T$). Form a pullback of c' along p_t :

$$\begin{array}{ccc}
 Q_t & \xrightarrow{c_t} & P_t \\
 q_t \downarrow & & \downarrow p_t \\
 Q & \xrightarrow{c'} & P
 \end{array}$$

Then c_t is a split epimorphism by (a) above, being a pullback of $f p_t$ along c . And c' is a λ -filtered colimit of these split epimorphisms, therefore it is a λ -pure quotient. \square

Remark 16. Let \mathcal{K} be an abelian λ -accessible category (or, more generally, a semi-abelian λ -accessible category in which all split monomorphisms are normal). Then λ -pure subobjects are stable under pullback along a λ -pure quotient. In fact, every semi-abelian category \mathcal{K} has the property that it has pullbacks, and split monomorphisms are stable under pullback along an epimorphism split by a normal monomorphism, see [2], Proposition 2. If \mathcal{K} is λ -accessible, then pullbacks commute with λ -filtered colimits. Therefore, λ -pure subobjects (which are precisely λ -filtered colimits of split monomorphisms, see [1]) are stable under pullback along a split epimorphism. From Proposition 4 we conclude that λ -pure subobjects are stable under pullback along λ -pure quotients.

Example. The above remark does not hold for accessible categories in general. Consider the following pullback in the category **Gra**:

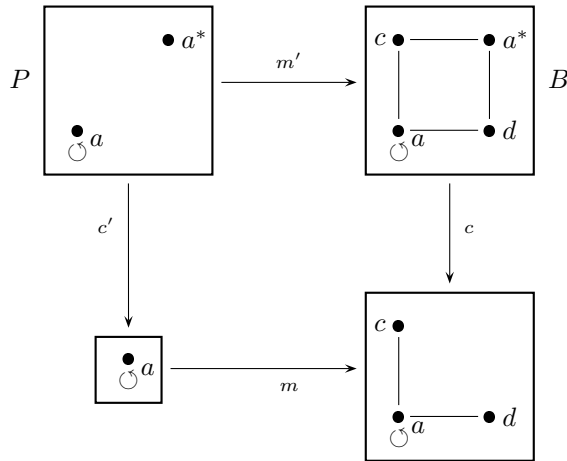

where c and c' map a^* to a and leave other nodes unmoved, and m , m' are the inclusion maps. Then m is a split subobject and c a split quotient. Nonetheless, m' is not pure: it is clear that m' is not split, and since B is finitely presentable, m' cannot be pure.

Acknowledgement. We are grateful to George Janelidze for a discussion on semi-abelian categories leading to Example 6.

References

- [1] *J. Adámek and J. Rosický*: Locally Presentable and Accessible Categories. Cambridge Univ. Press, Cambridge, 1994.
- [2] *D. Bourn*: Normal subobjects and abelian objects in protomodular categories. *J. Algebra* 228 (2000), 143–164.
- [3] *S. Fakir*: Objects algébriquement clos et injectifs dans les catégories localement présentables. *Bull. Soc. Math. France* 42 (1975).
- [4] *G. Janelidze, S. Márki and W. Tholen*: Semi-abelian categories.
- [5] *C. Lair*: Catégories modélables et catégories esquissables. *Diagrammes* (1981), 1–20.
- [6] *M. Makkai and R. Paré*: Accessible categories: The foundations of categorical model theory. *Contemp. Math.* Vol. 104. Amer. Math. Soc., Providence, 1989.
- [7] *P. Rothmaler*: Purity in model theory. In: *Advances in Algebra and Model Theory* (M. Droste and R. Göbel, eds.). Gordon and Breach, 1997, pp. 445–469.

Authors' addresses: J. Adámek, Technical University of Braunschweig, Germany, e-mail: J.Adamek@tu-bs.de; J. Rosický, Masaryk University, Brno, Czech Republic, e-mail: rosicky@math.muni.cz.